



# Roof De-Icing System

## INSTALLATION INSTRUCTIONS

Calorique

PCR-A2015

# LIMITED WARRANTY

Calorique LLC warrants that, at the time of shipment to the customer who directly purchases the Product (encapsulated heating element) from Calorique LLC, the product will be free of defects in workmanship and materials and will conform in all material respects to any written specification that Calorique LLC provided to that customer before the purchase.

If that customer believes that a shipment of product fails to satisfy the above warranty, that customer must (a) contact Calorique LLC in writing within 15 years after that customer receives the shipment, including a detailed explanation of the alleged nonconformity and (b) return the shipment to Calorique LLC postage prepaid. If Calorique LLC reasonably determines through examination of the returned shipment that the shipment did not satisfy the above warranty, then AS CALORIQUE LLC'S EXCLUSIVE LIABILITY AND THE CUSTOMER'S SOLE REMEDY, CALORIQUE LLC WILL, WITHIN A REASONABLE PERIOD OF TIME, REPAIR THE PRODUCT, REPLACE THE PRODUCT WITH THE SAME OR SIMILAR PRODUCT, OR CREDIT THE CUSTOMER'S ACCOUNT WITH THE PURCHASE PRICE, WHICHEVER CALORIQUE LLC MAY ELECT IN ITS SOLE DISCRETION.

This warranty does not apply if Calorique LLC reasonably determines that the product has been cut, added to or otherwise altered, stored improperly, misused, damaged, or installed not in accordance with the instruction manual supplied by Calorique LLC.

Except as expressly provided in this Limited Warranty, the customer is responsible for the cost of labor, service calls, insurance, shipping, installation costs and any other expense or damage incurred.

THE FOREGOING WARRANTY IS IN LIEU OF ALL OTHER REPRESENTATIONS, WARRANTIES, OR CONDITIONS, EXPRESS OR IMPLIED, INCLUDING WITHOUT LIMITATION ANY IMPLIED WARRANTY OF MERCHANTABILITY, FITNESS FOR A PARTICULAR PURPOSE OR NON-INFRINGEMENT, AND OF ANY OTHER OBLIGATION OR LIABILITY ON THE PART OF CALORIQUE LLC, WHETHER BY STATUTE, CONTRACT, STRICT LIABILITY, TORT OR OTHERWISE.

CALORIQUE LLC IS NOT RESPONSIBLE FOR ANY INCIDENTAL, CONSEQUENTIAL, MULTIPLE, PUNITIVE OR INDIRECT DAMAGES OR LOSS, LOSS OR DAMAGE TO OR LOSS OF USE OF FACILITIES OR OTHER PROPERTY, OR FOR LOST PROFITS OR LOST REVENUE, WHETHER BASED UPON WARRANTY, STATUTE, CONTRACT, STRICT LIABILITY, TORT OR OTHERWISE. CALORIQUE LLC SHALL IN NO EVENT BE LIABLE FOR THE PERFORMANCE OF, OR COST OF PERFORMING, THE REMOVAL OR INSTALLATION OF THE PRODUCT OR ANY PRODUCT OR MATERIAL INTO WHICH IT IS INSTALLED, INCORPORATED OR ADDED. THE CUSTOMER IS RESPONSIBLE FOR THE COST OF LABOR, SERVICE CALLS, INSURANCE, SHIPPING, INSTALLATION COSTS AND ANY OTHER EXPENSE OR DAMAGE INCURRED.

IN NO EVENT SHALL CALORIQUE LLC'S MAXIMUM LIABILITY EXCEED THE PURCHASE PRICE FOR THE RELEVANT SHIPMENT OF PRODUCT.

The above mentioned warranty is for the "encapsulated heating element" only. The warranty period for our controllers, connectors and any electrical plugs and jumpers are in accordance with the manufacturer of those components separately.

This product is not designed or intended to be sold directly to consumers or directly used for personal, family, or household purposes.

However, if the Product is deemed to be a consumer product in certain jurisdictions:

- The above exclusion or limitation of incidental or consequential damages and the above disclaimer of implied warranties may not apply.
- The term of any such implied warranty is limited to the term of this 15 year limited warranty. Some jurisdictions do not allow limitations on how long an implied warranty lasts, so the above limitations may not apply.
- Consumers may also have other rights, which vary by jurisdiction.

**Perfectly Clear™**



Perfectly Clear™ Roof De-Icing System Installation Manual  
PCR-A2015

Copyright © 2015 Calorique  
2380 Cranberry Highway  
West Wareham, MA 02576

# PERFECTLY CLEAR™ ROOF DE-ICING SYSTEM INSTALLATION

Perfectly Clear™ Roof De-Icing System is designed to prevent ice dams from forming when installed in accordance with the Manufacturer's Instructions. Perfectly Clear™ Roof De-Icing System melts snow and ice on roofs. Heating panels are installed between shingle courses underneath the exposure sections in areas where ice dams are likely to form or have been known to form. It is HIGHLY recommended that the system be used with an automated controller/sensor for purposes of product efficiency.

This installation manual is intended for installing Perfectly Clear™ Roof De-Icing System panels along with a Controller/Sensor. For other methods of installing the Perfectly Clear™ Roof De-Icing System without a controller, consult your licensed electrician.

---

## CAUTION



**Read and follow all the installation instructions in this manual before attempting to install the Perfectly Clear™ Roof De-Icing System. Improper installation procedures or techniques can cause potentially unsafe conditions, including overheating and shock hazards.**

**Failure to comply with the instructions in this manual will void the manufacturer's warranty.**

**Electrical Connections should be made only by licensed electricians.**

---

## NOTE



**Upon removing the heating panels from the box, it is important to check and record the resistance of each panel using a digital ohm meter, and compare those readings with the baseline resistance indicated on the stickers attached to the panels. If any panel shows a resistance reading that varies from the baseline value, call the technical support hotline at 1-800-922-9276.**

---

## NOTE



**Product must be stored at or below 68° F (20° C).**

---

# Table of Contents

<b>Safety Information</b> .....	iii
<b>Section 1. Introduction and Components</b> .....	1
How To Use This Manual .....	1
Specifications .....	1
Calorique Components .....	2
Tools Required.....	3
For Additional Help .....	3
<b>Section 2. Pre-Installation Checklist</b> .....	4
<b>Section 3. Designing the Installation</b> .....	6
Design Considerations .....	6
Design Clearances .....	7
Design Steps.....	8
<b>Section 4. Jobsite Preparation</b> .....	10
Install Junction Box and Optional Controller.....	10
<b>Section 5. Installation for New and Existing Asphalt Shingle Roofs</b> .....	10
Prepare the Layout.....	11
Check Heating Panels Before Installation.....	12
New Roof Installations.....	12
Retrofit Roof Installations.....	16
<b>Section 6. Installation in a Valley</b> .....	17
New Roof Installations.....	17
For Retrofitting an Existing Roof.....	17
<b>Section 7. Retrofit Installation Near Hip Caps</b> .....	18
<b>Section 8. Inspection and Testing</b> .....	19
Visual Inspection .....	19
Resistance Check.....	19
Documentation .....	19
<b>Section 9. Complete the Installation</b> .....	21
Power Cord Connection .....	21
Test for Heating.....	21
Troubleshooting.....	22
120V Heating Panels Resistance Limits.....	23
240V Heating Panels Resistance Limits.....	24
Color Match Chart.....	25

# Safety Information

Throughout the manual you will see Cautions and Notes. These notices highlight conditions, procedures, or other information that require special attention to prevent damage to the panels, to your property, or possible injury. For a safe and functional installation of Perfectly Clear™ Roof De-Icing System, read and follow these important safety precautions. Failure to comply with these items may result in injury or damage. This information must be read and understood by all technicians who will be working in the area of an installed Perfectly Clear™ Roof De-Icing System or main electrical systems. Failure to follow these guidelines may result in a risk of electric shock or fire hazard.



**Indicates precautions or procedures that should be followed to prevent the possibility of fire.**



**Indicates precautions or procedures that should be followed to prevent the possibility of electrical shock.**



**Indicates an item that you should pay special attention to. For example, notes are used to highlight installation tips.**

---

## CAUTION



**Ensure that the breaker supplying power to the heating panels has been turned off before making electrical connections.**

---

## CAUTION



**Do not fold, cut, or otherwise alter the heating panels.**

---

## Safety Information - Continued

---

### NOTE



Heating elements should not be installed at or below 32°F (0°C).

---

### NOTE



**THIS SYSTEM SHALL BE INSTALLED ONLY BY QUALIFIED PERSONNEL WHO ARE FAMILIAR WITH THE CONSTRUCTION AND OPERATION OF THE HEATING SYSTEM AND THE RISKS INVOLVED. IT IS RECOMMENDED A QUALIFIED LICENSED ELECTRICIAN IS UTILIZED FOR ALL ELECTRICAL CONNECTIONS.**

---

### NOTE



The installation of this heating product shall be in accordance with the manufacturer's instructions and the regulations of the authority having jurisdiction.

---

### NOTE



The installation of this heating product shall be in accordance with Article 426 of the National Electrical Code fixed outdoor electric de-icing and snow melting equipment, ANSI/NFPA 70. It is recommended a local permit be obtained prior to installation.

---

### NOTE



NEC: 426.28 - Ground Fault Protection of equipment shall be provided for fixed outdoor electric de-icing and snow melting equipment.

---

# Section 1. Introduction and Components

## How To Use This Manual

This manual is organized into the following sections:

- Section 1. Introduction and Components
- Section 2. Pre-Installation Checklist
- Section 3. Designing the Installation
- Section 4. Jobsite Preparation
- Section 5. Installation for New and Existing Asphalt Shingled Roofs
- Section 6. Installation in Roof Valleys
- Section 7. Inspection and Testing
- Section 8. Complete the Installation

## Specifications

- The Perfectly Clear™ Roof De-Icing System is in compliance with UL499 certified by ETL Intertek.
- The Perfectly Clear™ Roof De-Icing System heating panel connectors are waterproof, with a rating of IP-65
- UL Listed Connectors and UL recognized components

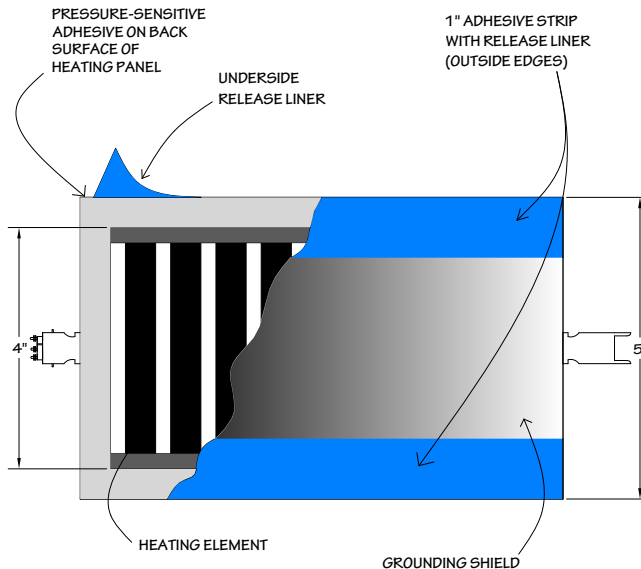

**Figure 1. Heating Panel Construction**

## Calorique Components

Item	Identification	Description
Roof De-ice Heating Panels (5" wide)	PCR5 5" Heating panels	Heating panel lengths are available in standard lengths of 3,4,5,10,20, 25' lengths. The number and type of heating panels must be calculated beforehand as outlined in the Design Phase. It is recommended that additional panels be on hand to cover any jobsite damage.
Valley Panels (10" wide)	PCR10 10" Valley heating panels	Valley panels are available in 3', 5', and 10' lengths.
Termination Plug	Male	Must be installed at the end of the run.
Power Cords (purchased separately)	COR8, COR9, COR12	5' single, 5' double, 5' triple
Jumper Cables (purchase separately)	COR4030S6, COR4030S, COR4030D, COR-4030-Jumper-S-18 COR-4030-Jumper-S-5, COR-4030-Jumper-S-10, COR-4030-Jumper-S-15	For connecting panels in sequence.
Controller/Sensor	See <a href="http://www.calorique.com">www.calorique.com</a> for recommended models.	Recommended for energy efficient operation.
Manual On/Off Switch	Must be rated for the applied voltage.	Controls power for the heating panels.
Warning Labels	CW1009, CW1016, CW1017, CW1018	Warning labels are an integral part of the system, and must be in place for the warranty to be in effect.
Instruction Manual	PCR-A2014	This booklet.



## Tools Required

Some of the tools listed below are needed only for retrofit installations and may not be required for installation with a new roof.

Item	Purpose
Flat bar or thin-bladed knife, such as a sheetrock taping knife	For lifting existing asphalt shingles
Digital Ohm Meter	An accurate ohm-meter or multi-meter must be used during the testing phase to ensure that the system is correctly installed. It is suggested that a digital meter is used rather than an analog needle type.

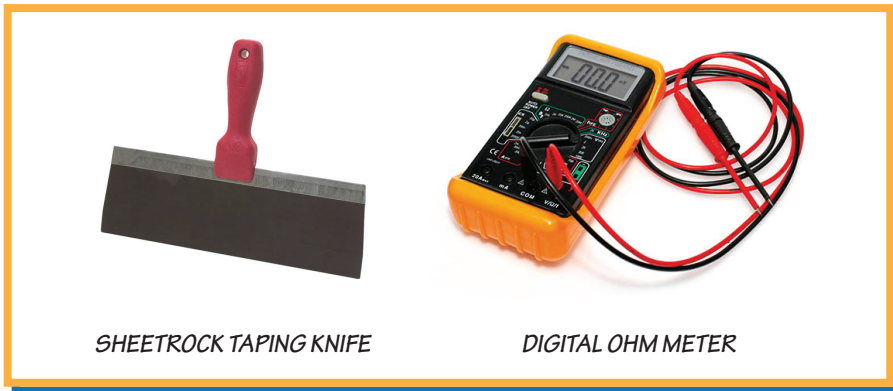

**Figure 2. Tools**

## For Additional Help

For additional help, the following resources are available:

- Technical Hotline: 1-800-922-9276
- Website: [www.calorique.com](http://www.calorique.com)
- Email: [technical@calorique.com](mailto:technical@calorique.com)

## Section 2. Pre-Installation Checklist



### NOTE

It is very important to perform a resistance check on the heating panels BEFORE installation.



Always check with your roofing contractor for any restrictions and/or requirements they may have concerning the use of this product in conjunction with their roofing products.

Each Perfectly Clear™ Roof De-Icing System heating panel has a sticker attached with the factory-tested resistance value for that specific panel. To ensure that your panels have not been damaged in shipping, you should use a digital ohm meter to check the resistance of each panel BEFORE it is installed.



**Figure 3. Heating Panels Factory Resistance Values**

Record the resistance readings that are required for warranty activation. The product label provides the factory tested resistance reading. The tested product resistance reading must be verified prior to installation. If the resistance reading is not within 3% of the recorded information on the label, do not install the product. Contact your supplier.

1. Perform a visual check to look for any signs of damage to the heating panels, connectors, or electrical leads that may have occurred during shipping. Specifically look for any signs of damage, wear, or scratching that might affect the electrical integrity of the installation. If any portion of a panel appears damaged, replace the entire panel. If damage is found, call 800-922-9276 for advice and/or replacement assistance.
2. Perform a resistance check immediately upon unpacking the heating panels using a digital ohm meter as shown in Figure 4. This will verify that the heating panels are in proper working order before they are adhered to the roof.
3. Record the resistance readings on the Checklist and Warranty form (see Figure 5).
4. If the resistance measured for any panel does not match the resistance value shown on the sticker, contact Calorique technical support at 1-800-922-9276 for assistance.

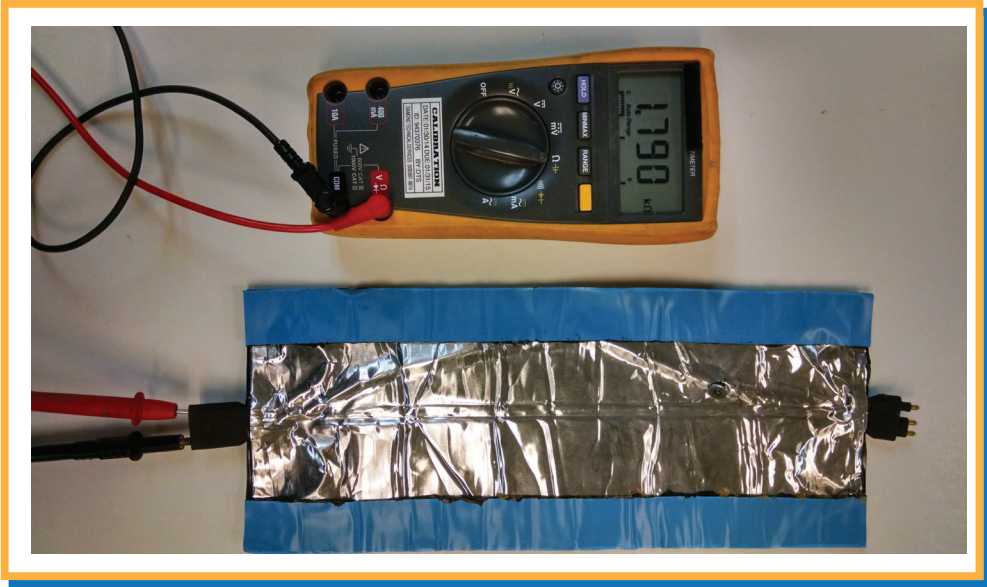

**Figure 4. Checking Resistance of Heating Panels**

**Calorique**  
Perfectly Clear™

## System Checklist and Warranty Registration

Name: \_\_\_\_\_ Name of Installer: \_\_\_\_\_  
 Installation Location: \_\_\_\_\_ Installer Company Name: \_\_\_\_\_  
 City/State/ZIP/Country: \_\_\_\_\_ Street Address: \_\_\_\_\_  
 Installation/Inspection Date: \_\_\_\_\_/\_\_\_\_\_/\_\_\_\_\_ City/State/ZIP/Country: \_\_\_\_\_  
 Purchase Order Number: \_\_\_\_\_ Electrical Inspector: \_\_\_\_\_  
 Purchased From: \_\_\_\_\_ Electrical Permit Number: \_\_\_\_\_

**Provide All Requested Information For Each Panel**

PRE INSTALLATION				
Number of Roof Panels Installed	Panel Length (FT)	Resistance Reading Before Installation	Visual Inspection*	
			A <input type="checkbox"/>	B <input type="checkbox"/>
			A <input type="checkbox"/>	B <input type="checkbox"/>
			A <input type="checkbox"/>	B <input type="checkbox"/>
			A <input type="checkbox"/>	B <input type="checkbox"/>

Record resistance readings here

**Figure 5. Recording Pre-Installation Resistance Check Values**

## Section 3. Designing the Installation

Perfectly Clear™ Roof De-Icing System is made up of heating panels, power cords, jumpers, and an optional control device. Your installation may require additional jumper cables. Along with the building structure itself, these components work together to create a system that will provide trouble-free heat. The selection and installation of each component is very important to the system's overall safe operation. Designing the Perfectly Clear™ Roof De-Icing System is straightforward – the following instructions must be completed to ensure a trouble-free design and comply with the warranty requirements.

### Design Considerations

The configuration of your Perfectly Clear™ Roof De-Icing System heating panels will be dependent on the unique characteristics of your roof. The heating panels should be installed in logical locations to prevent the formation of ice dams or other accumulations of ice (see Figure 6). Consideration should be given to the orientation of the roof, valleys alongside gables, chimneys, and other features of your specific roof. Generally speaking, the heating panels are installed above the starter strip and below the first course exposure. Additional courses may be necessary depending upon the depth of the overhang, and the snow loads in your area. Extra attention should be placed on the North Facing Side of your roof as ice dams typically form on North facing side of structures. For complex roof lines, suggested areas of placement is in areas of deep shadows.

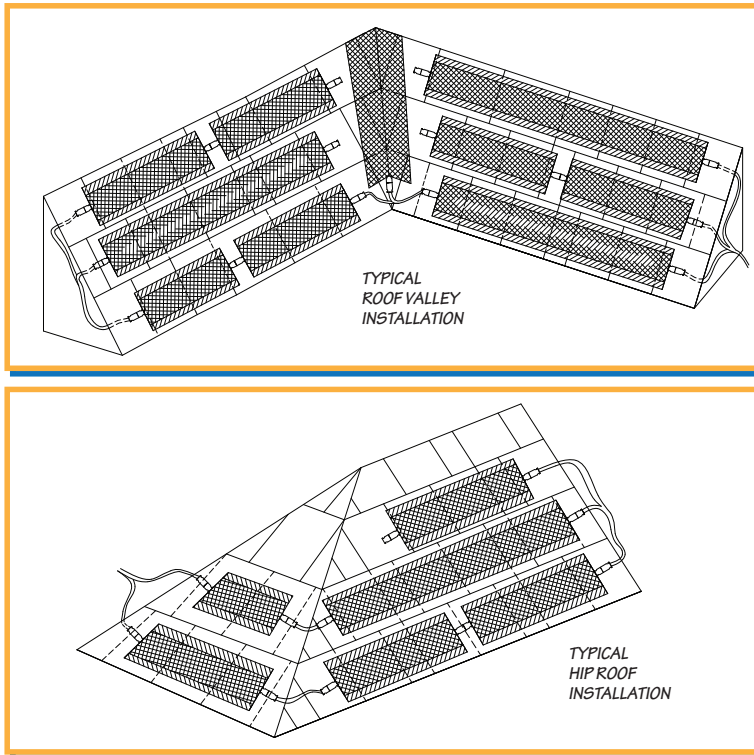

**Figure 6. Typical Installations**

## Design Clearances

---

### CAUTION



Perfectly Clear™ Roof De-Icing System heating panels must be installed so they will not be covered, even in part by any structures, fixtures, flashing including vents and pipes located on the roof. Heating panels which are covered by any structure may overheat.



Power Cords and Jumpers may NOT be installed underneath or on top of heating panels.

---

**Permanent Fixtures** - Calorique heating panels must be installed so they will not be covered, even in part, by any structures, fixtures, flashing including vents and pipes located on the roof. Heating panels which are covered by any structure may overheat.

**Overlap** - Overlapping of the product is not permissible.

**Heat Sources** - At least 4 inches (10cm) of clearance must be maintained between heat sources such as chimneys and the Calorique Heating Panels.

**Roof Vents** - At least 2 inches (50 cm) of clearance must be maintained between any pipes (metal or plastic) and the Calorique heating panels.

**Snow Load** - Depending upon the snow loads in your area, additional multiple courses may be required.

**Overhangs** - Depending upon the depth of the overhang, it is recommended the heating panels are installed and extend back to the beginning of the overhang.

**Complex Roof Designs** - It is recommended that the heating element is installed in areas of deep shadows .

**North Sides** - Extra attention should be placed on North facing side as ice dams typically form on north facing sides of structures.

**Configuration** - Your specific configuration may require the use of jumper cables. These accessories are purchased separately and are typically used to connect the runs of heating panels across roof valleys or other roof features. They are available in 18-inch, 5-foot, 10-foot, and 15-foot lengths.

**End of Runs** - Termination plugs at ends of runs must be concealed under the shingle at all times.

## Design Steps

1. Determine the best location for the electrical junction box to be used to connect power to the heating panels.
2. Determine the best location for a control device and the routing for the electrical wiring. A qualified (licensed) electrician is recommended to make all connections and wiring in accordance with local building code.

---

### CAUTION



**When connecting multiple heating panels in a series, the overall length of any single run cannot exceed 48 feet for 120V product, and 96 feet for 240V product.**

- 
3. Measure the important dimensions of your roof (see Figure 7) and sketch your plan layout.
  4. Measure the length (in feet) of the runs of heating panels required, and the number of courses to be filled. Use this information to determine how many heating panels will be required for your particular roof configuration.
  5. Determine the combinations of panel lengths required to fill your run.
  6. For lengthy runs, it is recommended that multiple heating panels are used rather than a single panel. This is the preferred method, rather than installing one long continuous heating panel.
  7. Your specific configuration may require the use of jumper cables. These accessories are available and are typically used to connect runs of heating panels across roof valleys or other roof features. The jumper cables are purchased separately. They are available in 18-inch, 5-foot, 10-foot, and 15-foot lengths. Contact your Calorique Perfectly Clear™ Roof De-Icing System supplier.

---

### NOTE



**All connections between heating panels MUST be underneath shingles when installation is completed. Additionally, all runs of heating panels connected in series MUST have a termination plug installed in the female socket of the last heating panel in the run.**

---

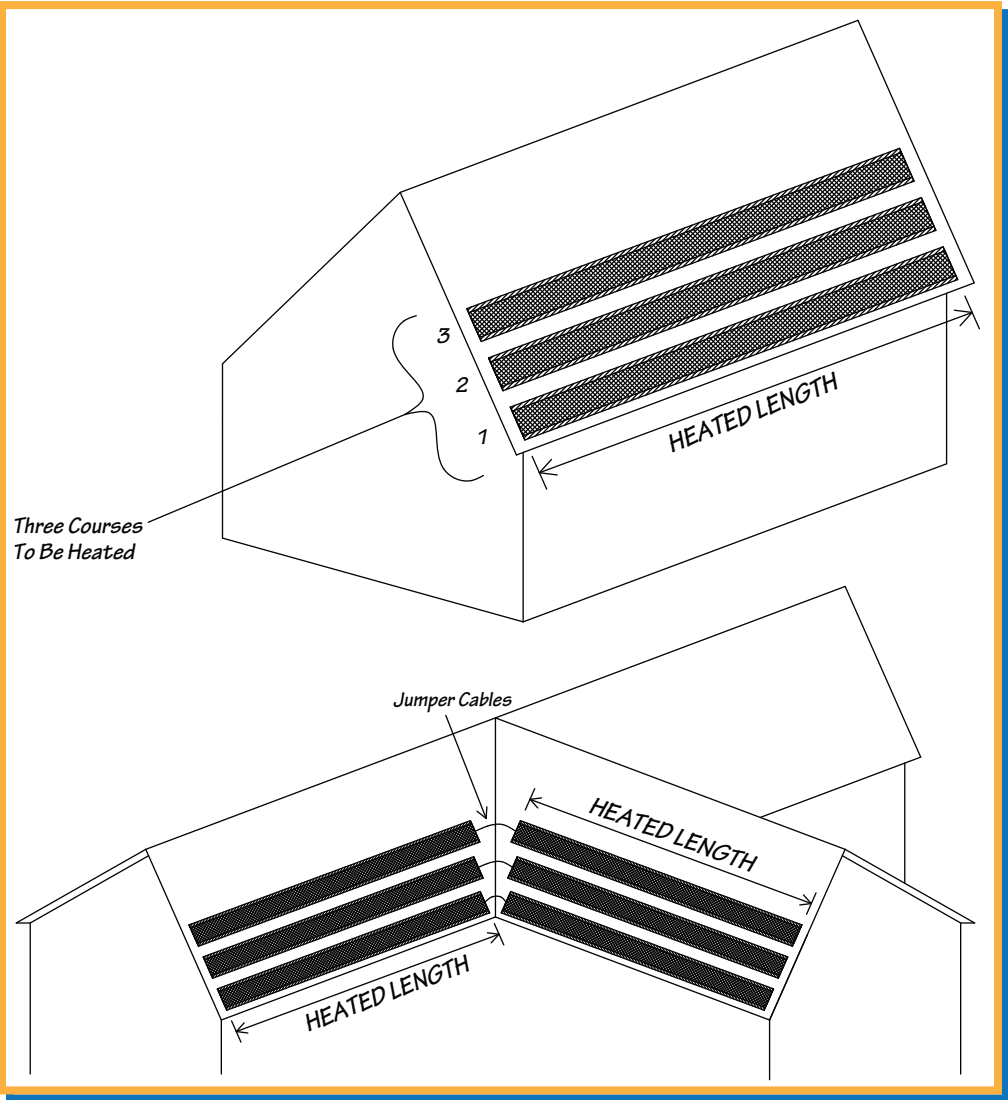

**Figure 7. Measuring the Length of Runs**

## Section 4. Jobsite Preparation

Before you can proceed, all electrical wiring that will not be accessible after the installation of the heating system must be completed. This may require coordinating with the licensed electrician.

---

### CAUTION



**Make sure that the jobsite is neat and clean before working with the Perfectly Clear™ Roof De-Icing System heating panels. Nails, screws, and other sharp debris can damage the panels. Any panel which becomes torn or otherwise damaged must be discarded.**

---

### Install Junction Box and Optional Controller

1. Install a wired junction box along the rake edge or under the eave.
2. Install controller or weather sensing device.
3. Remove end plug leaving enough wire to accommodate drip loop and make connections in exterior grade junction box per National Electric Code.
4. Install the system controller and connect it to the junction box, but **DO NOT CONNECT POWER AT THIS TIME**. See wiring instructions for controller.

## Section 5. Installation for New and Existing Asphalt Shingle Roofs

---

### NOTE



**All wiring, fuses, and/or circuit breakers must conform to National Electric Code.**

---

### NOTE



**All connections to the roof De-Ice Panels must be made using Calorique supplied accessories. Refer to “Calorique Components” on Page 2 for a list of genuine Calorique accessories.**

---



## Prepare the Layout

Perfectly Clear™ Roof De-Icing System Heating panels come in multiple lengths. Each panel has one male and one female connector attached. Heating panels are available in custom lengths up to 50 feet from Calorique. Contact your distributor for details.

### CAUTION



**Calorique Perfectly Clear™ Roof De-Icing System heating panels cannot be cut or altered.**

Lay out the heating panels with the male/female connectors properly oriented so that they can be connected together to span the entire run, as determined in the Design phase. At the end of each run, a termination plug must be installed in the last female connector on the run (see Figure 8).

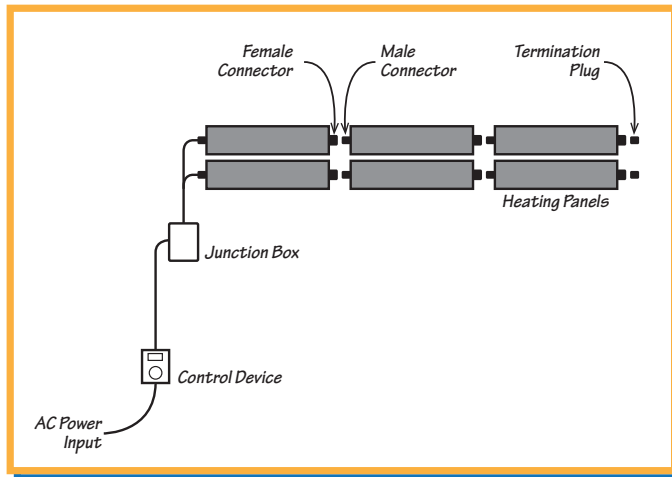

**Figure 8. Simplified Installation Diagram**

## Check Heating Panels Before Installation

---

### NOTE



**It is very important to perform a resistance check on the heating panels BEFORE installation.**

---

Each Perfectly Clear™ Roof De-Icing System heating panel has a sticker attached with the factory tested resistance value for that specific panel. To ensure that your panels have not been damaged in shipping, you should use a digital ohm meter to check the resistance of each panel BEFORE it is installed. If the resistance reading for any panel is not within 3% of the resistance value shown on the sticker, contact Calorique technical support at 800-922-9276.

## Installing the Heating Panels

---

### NOTE



**Always check with your roofing contractor for any restrictions and or requirements that they have concerning the use of this product in conjunction with their roofing products.**

---

## New Roof Installations

---

### CAUTION



**Do not nail through the panels.**

---

1. For new construction installations, Perfectly Clear™ Roof De-Icing System is installed between the starter strip and the 1st course exposure. Additional courses are generally necessary.
2. Begin by installing the heating panels on top of the starter strip and underneath the first course exposure. Do not nail. Additional courses may be necessary.
3. Ensure all heating panels are installed a minimum of 6 inches from the rake edge of the roof deck (not including the overhang) (see Figure 9).

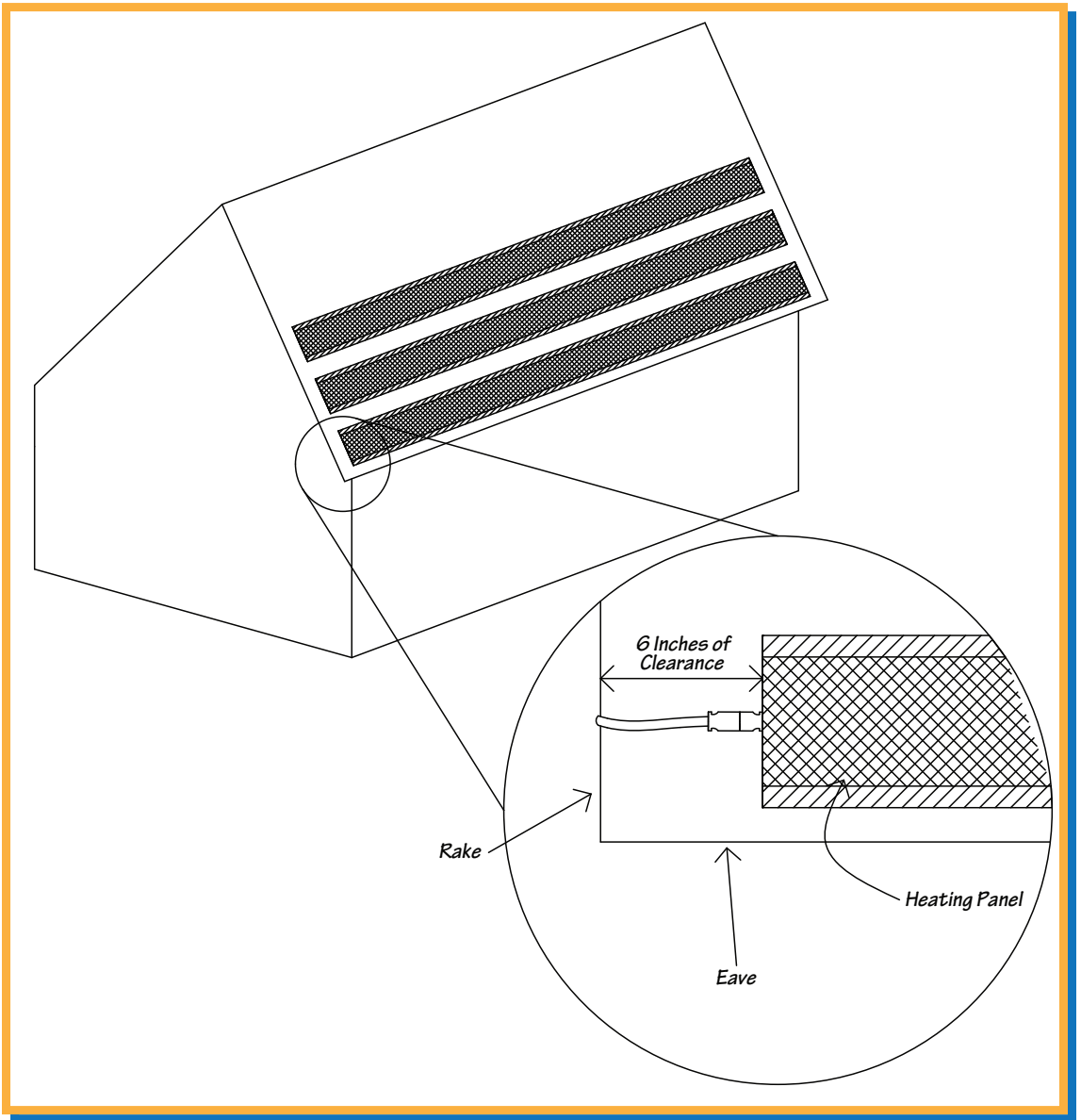

**Figure 9. Proper Spacing From Shingle Edge**

4. Position the next heating panel and plug the male connector into the female of the adjacent panel.

5. Heating panels should be installed below the nailing line (see Figure 10).

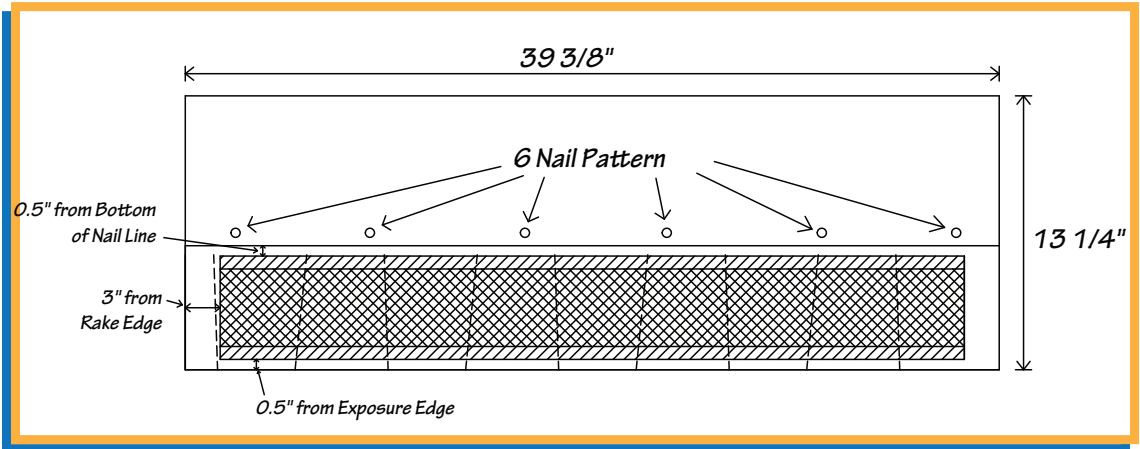

**Figure 10. Proper Nailing Pattern**

6. Remove underside release liner and press to adhere (see Figure 11).

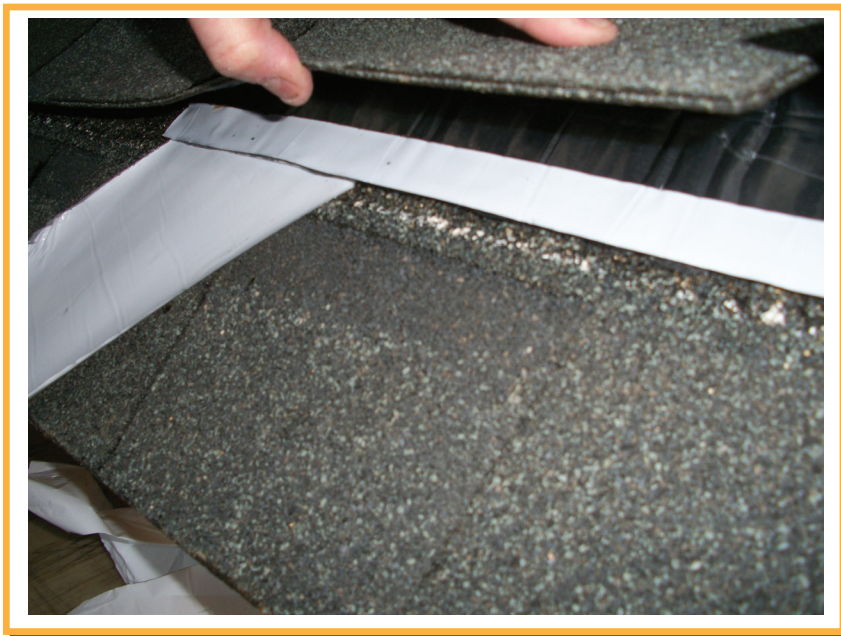

**Figure 11. Removing Release Liner**

7. Install additional heating panels under additional shingle courses.
8. All power connections must be underneath the shingle and should not be exposed.

9. An additional course may be necessary. Repeat steps for additional courses making sure no single run is longer than 50' of panels.
10. After all panels have been installed in the run, plug the male termination plug into the final female connection on the last heating panel.

---

**NOTE**



**All electrical connections and supplies must be in compliance with the National Electric Code.**

**Extension cords are NOT permitted.**

---

11. Connect the Perfectly Clear™ Roof De-Icing System to the controller by using a power cord or hardwiring,
12. After connecting the Perfectly Clear™ Roof De-Icing System to the controller by using a power cord or hardwiring, secure the cord in place with insulated staples to prevent additional stress on the black connectors due to the movement of the cord. It is important to include a drip loop as indicated in Figure 12.

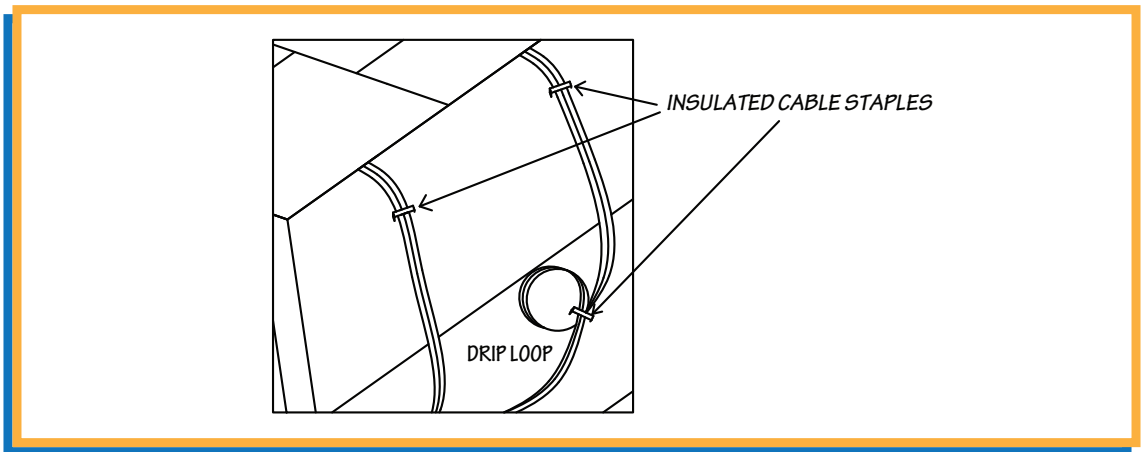

**Figure 12. Proper Drip Loop Configuration**

## Retrofit Roof Installations

1. In retro-fit applications, gently lift shingles using wide flat tool such as a drywall taping knife (see Figure 13).

---

### NOTE



**Use extreme caution lifting older shingles. If older shingles are cracked or become damaged please replace.**

---



***Figure 13. Lifting Shingles for Installation of Heating Panels***

2. Slide panel under the shingle exposure while making certain the heating panel is 6 inches away from the rake edge (see Figure 9).
3. Position the next heating panel and plug the male connector of the next heating panel into the female connector of the previous panel.
4. Remove the release liner and press to adhere (see Figure 11).
5. Repeat for any additional required courses.
6. After all panels have been installed in the run, plug the male termination plug into the final female connection on the last heating panel of the run.
7. After connecting the roof de-icing system to the controller by using a power cord or hardwiring, secure the cord in place with insulated staples to prevent additional stress on the black connectors due to the movement of the cord. It is important to include a drip loop as indicated in Figure 12.
8. For installation of heating panels underneath 3-tab shingle styles, it is required to paint the exposed areas of the heating panel. To achieve desired color match for either the shadow line or shingle color, please refer to the chart on page 23. The entire panel may be painted prior to install or the exposed areas can be painted after installation for existing 3-tab shingled roofs.

# Section 6. Installation in a Valley

## New Roof Installations

1. Peel the liner from the back of the roof de-icing panel.
2. Adhere the panel to the valley deck, on top of ice and water shield.
3. Connect using dual split dual jumper (Part Number COR-4030D) to the adjacent roof de-icing panel under the shingle.

## For Retrofitting an Existing Roof

1. Dry fit the panel on top of the valley shingles located in the valley.
2. For instances when the valley de-ice panel is installed on top of the existing asphalt shingles, it is required to paint the valley de-icing panel. Please refer to the color match chart on page 23.
3. For instances of open valley configuration, roof deicing panel should be installed on the top of the metal flashing.
4. Peel the liner back 1 inch from the non-connector end.
5. Position the valley heating panel, completely remove the underside liner.
6. Firmly press down on the exposed adhesive (to ensure good adhesion), working your way to the connector end of the heating panel, pressing as you go.
7. Connect the valley heating panel to the adjacent roof de-icing heating panel using a Jumper Cable.
8. It is required to paint the valley deicing panel when installed as a retro-fit on top of existing shingles. Use the chart on page 23 to assist in selecting a color that will match the shingles on your roof.

## Section 7. Retrofit Installation Near Hip Caps

1. Break Seal between A and B.
2. Remove Nails on Starter Strip {A}
3. Slide Heating Element under shingle on hip and ridge and jumper under cap {B}
4. Use new starter cap {A} and nail down. Be careful not to nail through heating element.
5. Break seal on next few cap courses {C} as necessary. Install heating elements
6. Apply standard roofing adhesive under caps where seals have been broken.

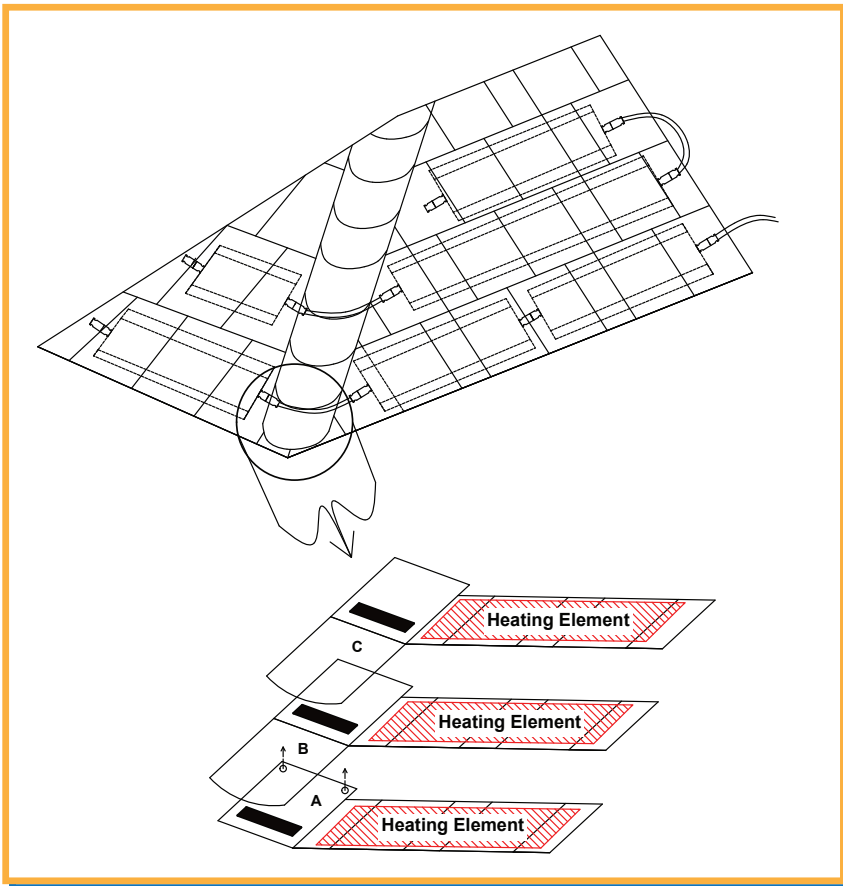

**Figure 14. Retrofit Installation Near Hip Roof Caps**



# Section 8. Inspection and Testing

## Visual Inspection

Also perform a visual check to look for any signs of damage to the heating panels, connectors, or electrical leads that may have occurred during installation. Specifically, look for any signs of damage, wear, or scratching that might affect the electrical integrity of the installation.

## Resistance Check

A second resistance check must be performed before powering the system. In order to activate the warranty, the resistance readings must be recorded on the warranty registration form. See Figure 16.

---

### NOTE



**After the heating panels have been installed, record the resistance readings that are required for the warranty registration. If the reading fails the resistance check, it must be retested after any corrective actions have been made.**

---

You must perform a resistance check across the panel runs using a digital ohm meter to detect any short or open circuits. The following formula is used to determine the high and low resistance limits for your installation:

Product	High Resistance Limit (ohms)	Low Resistance Limit (ohms)
120 Volts	$15840 \div \text{Total Installed Watts}$	$13680 \div \text{Total Installed Watts}$
240 Volts	$63360 \div \text{Total Installed Watts}$	$54720 \div \text{Total Installed Watts}$

To determine the total installed watts, add the watts per panel found in the chart on pages 23 and 24.

Please refer to the following illustration to calculate the high and low limit resistance values: For example, you installed two panels at 5 ft. each rated at 120 Volts. Each panel carries 48.07 watts (from the chart on page 23).

Total Installed watts = number of panels multiplied by watts per panel

$$\text{Total Installed watts} = 2 \times 48.07 = 96.14$$

$$\text{High Resistance Limit} = 15840 \div \text{Total Installed Watts} = 15840 \div 96.14 = 164.76 \text{ ohms}$$

$$\text{Low Resistance Limit} = 13680 \div \text{Total Installed Watts} = 13680 \div 96.14 = 142.29 \text{ ohms}$$

Resistance value across the panel runs should be within high and low resistance limits.

## Documentation

The System Checklist and Warranty Registration form records vital information about your installation. Fill out all requested information on BOTH copies. One copy is returned to the manufacturer to register the installation, and the second copy is for the homeowner's records. This manual must be attached to the service panel so that it is easily accessible to the homeowner and any repair technicians.

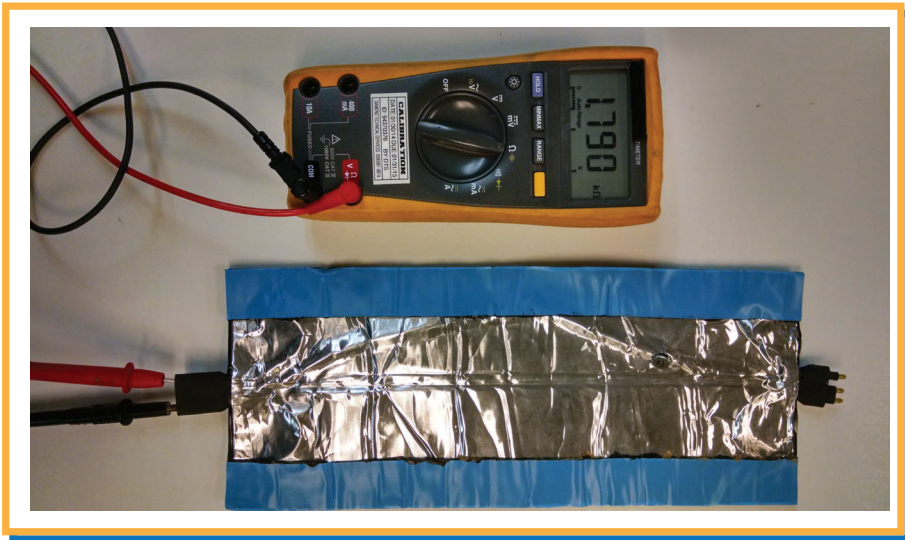

**Figure 15. Checking Resistance**

**Record resistance readings here**

### System Checklist and Warranty Registration

Name: \_\_\_\_\_ Name of Installer: \_\_\_\_\_  
 Installation Location: \_\_\_\_\_ Installer Company Name: \_\_\_\_\_  
 City/State/ZIP/Country: \_\_\_\_\_ Street Address: \_\_\_\_\_  
 Installation/Inspection Date: \_\_\_\_\_ City/State/ZIP/Country: \_\_\_\_\_  
 Purchase Order Number: \_\_\_\_\_ Electrical Inspector: \_\_\_\_\_  
 Purchased From: \_\_\_\_\_ Electrical Permit Number: \_\_\_\_\_

**Provide All Requested Information For Each Installation**

PRE INSTALLATION				POST INSTALLATION	
Number of Roof Panels Installed	Panel Length (FT)	Resistance Reading Before Installation	Visual Inspection*	Length of Run or Course	Resistance Reading After Installation
			A <input type="checkbox"/> B <input type="checkbox"/>		
			A <input type="checkbox"/> B <input type="checkbox"/>		
			A <input type="checkbox"/> B <input type="checkbox"/>		
			A <input type="checkbox"/> B <input type="checkbox"/>		

**Figure 16. Recording Resistance Readings**

# Section 9. Complete the Installation

## Power Cord Connection

1. Attach the power cord to the first panel male connector in the run.
2. Hard wire or plug the power cord into the power source or optional controller/sensor.

---

### NOTE



**To provide continued protection against risk of electrical shock, connect to properly grounded outlets only.**

---

---

### NOTE



**To avoid nuisance breaker tripping, it is strongly suggested to use a GFEP Breaker instead of a GFCI Breaker.**

---

## Test for Heating

1. Turn on the circuit breaker and adjust the controller so that the system begins warming.
2. Once the system has been turned on for several minutes, run your hand over the shingles to ensure they are warm.
3. If shingles do not become warm, turn power off and check circuit breaker, check wiring, check power to house.
4. Make certain the appropriate power 120V or 240V is applied to the system.
5. After any corrections are made, repeat Steps 1 and 2.
6. Please read and follow the instructions for controller programming.

---

### NOTE



**After performing the steps in the trouble shooting guide, and actions have been performed to repair and electrical faults, the heating panels MUST be retested.**

---

# Troubleshooting

It is important that this manual be followed during the installation procedures and that all warnings be followed. Wiring should be performed by a licensed electrician in accordance with all applicable building and electrical codes during the installation as well as for any trouble shooting of the system. Failure to do so voids warranty.

A resistance check must be performed on all panels. The manufacturer will not be responsible for the replacement of roofing components if the system operation was not checked and verified prior to the installation of the system.

Symptom	Corrective Actions
Individual Panel Not Warming	Check the power source and verify all the connections are properly made. Check for any damage to the power cords and jumpers.
Overheating	Verify that 240V power is not being applied to deicer panels rated for 120V service.
Controller Issues	Refer to the controller manufacturer's documentation.

# Place Warning Labels

Apply provided warning labels in appropriate locations as indicated below. These labels are an integral part of this heating system and must be installed for warranty to be in force.

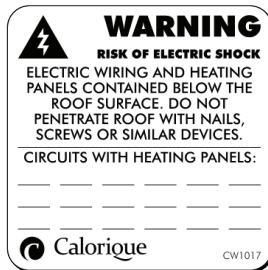

CW1017: Affix to the electrical panel box. In the space provided, record the numbers of all circuits to roof deicer systems are attached.



CW1018: Affix to all devices controlling the roof deicer system.



CW1016: Affix adjacent to points of access to all concealed areas in which installed deicing products are accessible.



CW1009: Affix adjacent to points of access to all concealed areas in which installed deicing products are accessible.

## 120V Heating Panels Resistance Limits

PRODUCT ID	WIDTH (IN)	LENGTH (FT)	WATTS	AMPS
PCR5-18W120V	5"	2	18.07	0.16
PCR5-28W120V	5"	3	28.07	0.23
PCR5-38W120V	5"	4	38.07	0.33
PCR5-48W120V	5"	5	48.07	0.42
PCR5-98W120V	5"	10	98.07	0.86
PCR5-118W120V	5"	12	118.07	0.98
PCR5-128W120V	5"	13	128.07	1.07
PCR5-148W120V	5"	15	148.07	1.23
PCR5-168W120V	5"	17	168.07	1.40
PCR5-178W120V	5"	18	178.07	1.48
PCR5-198W120V	5"	20	198.07	1.74
PCR5-248W120V	5"	25	248.07	2.18
PCR5-298W120V	5"	30	298.07	2.61
PCR5-398W120V	5"	40	398.07	3.49
PCR5-498W120V	5"	50	498.07	4.37
PCRV10-46W120V	10"	2	45.76	0.40
PCRV10-114W120V	10"	5	114.40	1.00
PCRV10-137W120V	10"	6	137.28	1.20
PCRV10-229W120V	10"	10	228.8	2.01

## 240V Heating Panels Resistance Limits

PRODUCT ID	WIDTH (IN)	LENGTH (FT)	WATTS	AMPS
PCR5-18W240V	5"	2	18.07	0.08
PCR5-28W240V	5"	3	28.07	0.12
PCR5-38W240V	5"	4	38.07	0.17
PCR5-48W240V	5"	5	48.07	0.21
PCR5-98W240V	5"	10	98.07	0.43
PCR5-118W240V	5"	12	118.07	0.49
PCR5-128W240V	5"	13	128.07	0.53
PCR5-148W240V	5"	15	148.07	0.61
PCR5-168W240V	5"	17	168.07	0.70
PCR5-178W240V	5"	18	178.07	0.74
PCR5-198W240V	5"	20	198.07	0.87
PCR5-248W240V	5"	25	248.07	1.09
PCR5-298W240V	5"	30	298.07	1.31
PCR5-398W240V	5"	40	398.07	1.75
PCR5-498W240V	5"	50	498.07	2.18
PCRV10-46W240V	10"	2	45.76	0.20
PCRV10-114W240V	10"	5	114.40	0.50
PCRV10-137W240V	10"	6	137.28	0.60
PCRV10-229W240V	10"	10	228.8	1.00

# Color Match Chart

<b>GAF Paint Color</b>	<b>GAF ShingleMatch</b>	<b>GAF Timberline</b>	<b>GAF Strip Shingle</b>	<b>GAF Designer</b>	
Charcoal	Charcoal	Charcoal Appalachian Sky	Charcoal	Canterbury Black Sheffield Black	Charcoal Black Oak
Shakewood	Shakewood	Shakewood Golden Harvest Copper Canyon	Golden Cedar SummerSage Cedar Shake Desert Sand Cypress Tan	Cedar Shakewood	
Slate	Slate	Slate Nantucket Morning	Slate	Slate Storm Cloud Gray	Harbor Mist
Hickory	Hickory	Hickory Adobe Sunset	Autumn Brown	Sedona Sunset Adobe Sunset	Mesa Brown
Weathered Wood	Weathered Wood	Weathered Wood Cedar Falls	Weathered Gray	Weathered Slate Weathered Wood	Aged Oak Cedarwood Abbey
Hunter Green	Hunter Green	Hunter Green			
Barkwood	Barkwood	Barkwood Saddlewood Ranch	Ash Brown Harvest Brown	Autumn Brown Stonewood	Barkwood Tuscan Sunset
Pewter Gray	Pewter Gray	Pewter Gray Williamsburg Slate Oyster Gray	Nickel Gray Stone Gray	Antique Slate English Gray Welsh Gray	Williamsburg Slate Castlewood Gray Chateau Gray
Birchwood	Birchwood	Birchwood			
Driftwood	Driftwood	Driftwood	Sandrift		
Fox Hollow Gray	Fox Hollow Gray	Fox Hollow Gray White Arctic White	Silver Lining White		
Mission Brown	Mission Brown	Mission Brown		Mission Brown Monticello Brown	
<b>GAF Paint Color</b>	<b>GAF TruSlate</b>	<b>GAF Liberty</b>	<b>Certainteed</b>	<b>TAMKO</b>	
Charcoal	Onyx Black	Black	Moire Black Charcoal Black	Rustic Black Black Walnut	
Shakewood		Shakewood Tan	Resawn Shake	Rustic Cedar	
Slate	Meadow Green Autumn Dusk	Slate	Georgetown Gray Granite Gray	Oxford Grey Thunderstorm Grey	
Hickory		Hickory	Burnt Sienna	Rustic Redwood Autumn Brown	
Weathered Wood		Weathered Wood	Weathered Wood	Weathered Wood Natural Timber	
Hunter Green			Hunter Green	Rustic Evergreen	
Barkwood			Heather Blend	Rustic Slate	
Pewter Gray	Greystone Mystic Grey Charcoal		Pewter	Virginia Slate Antique Slate	
Birchwood		White	Birchwood		
Driftwood			Sunrise Cedar		
Fox Hollow Gray			Cobblestone Gray	Old English Pewter Glacier White	
Mission Brown			Mission Brown		

**Perfectly**  **Clear**™

Copyright © 2015 Calorique, LLC.  
2380 Cranberry Highway  
West Wareham, MA 02576  
1-800-922-9276  
[www.calorique.com](http://www.calorique.com)